

# Hydraulic pipe benders



For GAS pipes, DIN 2440 and DIN 2441.  
Maximum bending angle: 180°. Supplied in a wooden case, with tripod stand and complete instructions for use, maintenance and bending work.

CVT-3A

Bending work can be carried out without physical effort thanks to the high force of the hydraulic unit (CVT-2, 15t; CVT-3, 20t).

Fitted with retractable bending frames, indelibly marked, to facilitate easier positioning of bending supports and pipe.

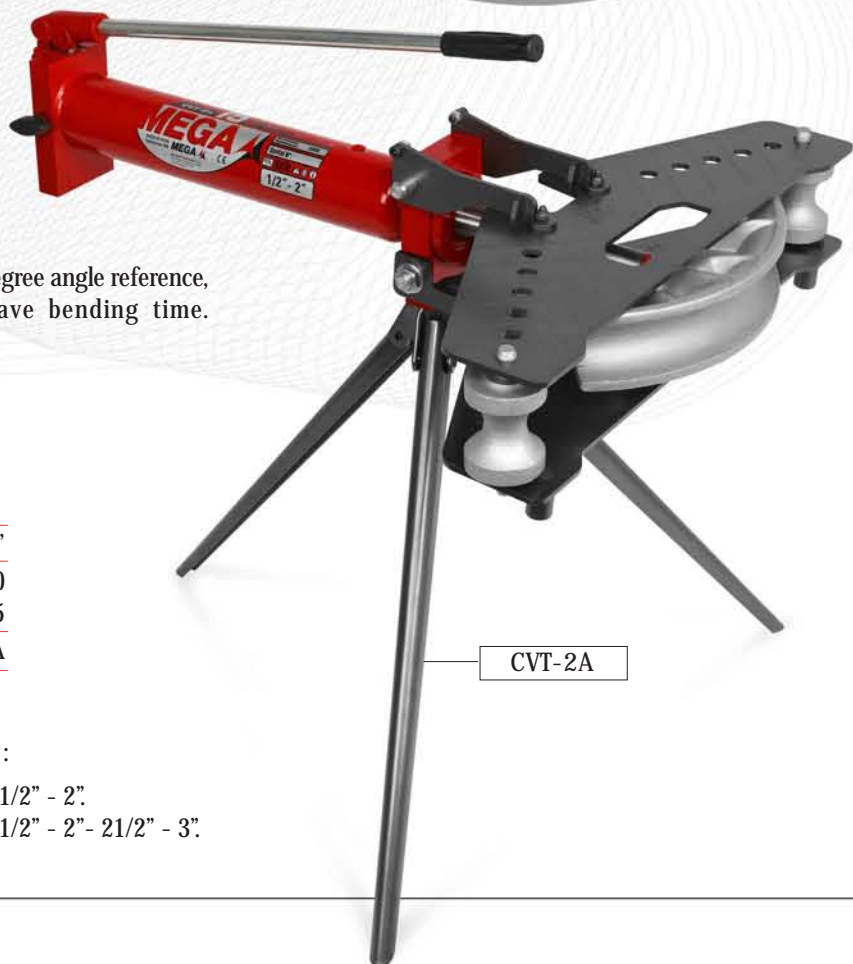
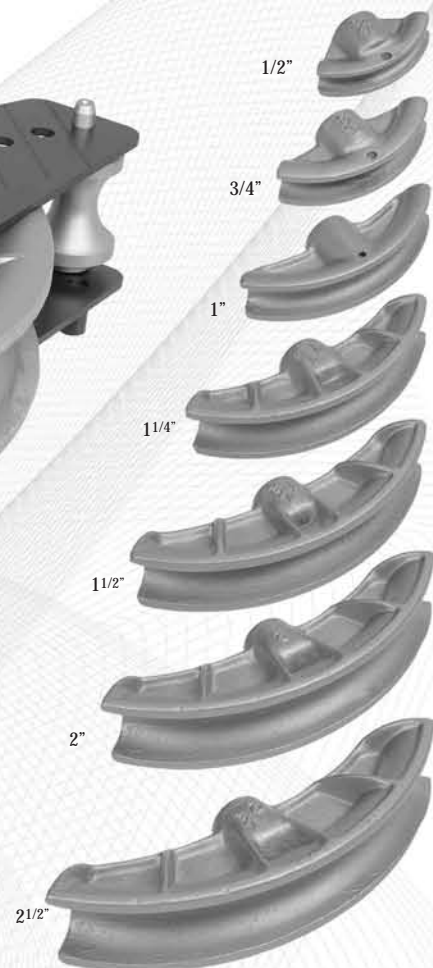

CVT-2A

“V” shape frames, showing the 90° degree angle reference, reduce hydraulic stroke and save bending time.

Safety overload valve.  
Hydraulic stroke limitation.  
Piston retracts by spring.

Pipes up to	2"	3"
Capacity (t)	15	20
Weight (kg)	59	110.5
Reference	CVT-2A	CVT-3A

Supplied with the following sets of formers:

CVT-2A: 1/2" - 3/4" - 1" - 1 1/4" - 1 1/2" - 2"

CVT-3A: 1/2" - 3/4" - 1" - 1 1/4" - 1 1/2" - 2" - 2 1/2" - 3"