



A-5181
Rubber pad for the saddle. Optional.



C-17
Extra saddle. Optional.



A-5187
The rotating handle can hold a box for screws. Box optional.



PF-1200A
Adjustable saddle with chains. Optional.



PF-1200A
Block of protective foam (A-5183). Optional.



For use in pits and underneath elevated vehicles. The lifting and lowering of the load using the foot pedals allow the hands to be free for other jobs. Easily manoeuvrable thanks to the five swivel castors. The large base size provides high stability under load. With ergonomic swivel handle.

FMG-300

LCS lowering control system.
"Dead man's" principle operation.
Safety overload valve.
Hydraulic stroke limitation.

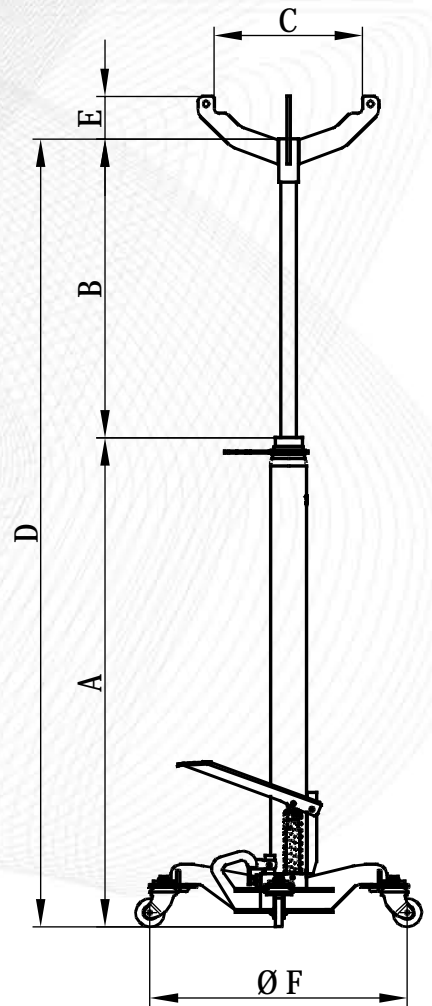

Capacity (kg)	300	750	1200	1200
A	1150	1138	1138	845
B	850	820	815	1000
C	304	304	304	304
D	2000	1958	1953	1845
E	89	89	89	89
F	630	750	750	750
Weight (kg)	28	32	35,5	35,5
References	FMG-300	FMG-750	FMG-1200	FMGT-1200

High lift transmission jacks



Newly designed support for holding oil containers.



A-5184
Adjustable support for oil-collection containers of different formats or diameters. Maximum diameter 485 mm. Optional.



A-5183
Block of protective foam. Optional.



FMG-750



FMG-1200



FMGT-1200
Telescopic