

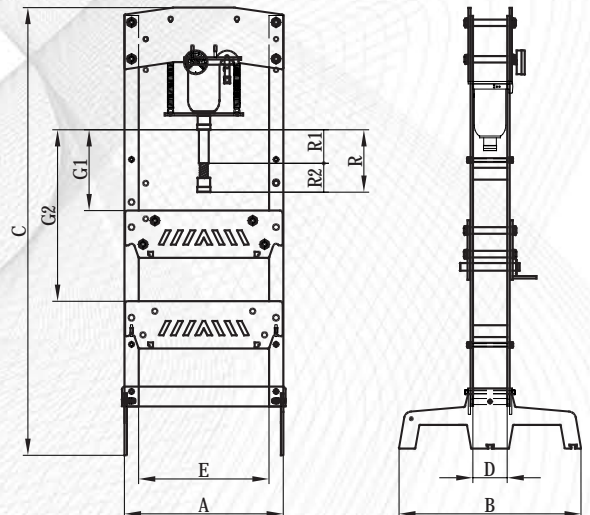

A-5552/15: For 15 t presses.
 A-5552/30: For 30 and 50 t presses.
 Adapter and set of punches. Ø30 25 22 20 18 16 12

The punches tray is delivered with the press but the set of punches is optional.



BUREAU VERITAS
 CE official certification

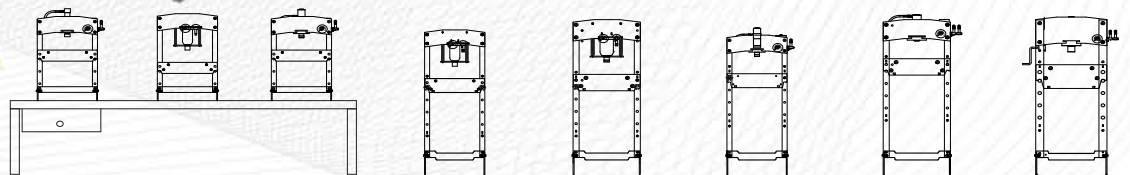

Capacity (t)	10	15	15	15	30	15	30	50
Measures (mm)								
A	600	600	600	600	670	600	670	710
B	450	450	450	770	770	770	770	770
C	1125	1060	1050	1735	1860	1760	1920	1895
D	120	120	120	120	145	120	145	145
E	500	500	500	500	550	500	550	550
G1 Minimum	160	150	150	150	150	150	155	155
G2 Maximum	460	300	450	660	680	660	690	715
R1 Hydraulic stroke	135	150	95	150	150	95	120	120
R2 Extension stroke	-	75	75	75	75	75	75	75
R Total stroke	135	225	170	225	225	170	195	195
Weight (kg)	71	69	74	81	131	86	135	206
References								
With manual pump	KSC-10	KSG-15	KSC-15	KMG-15	KMG-30	KCK-15	KCK-30	KCK-50
With BKN-09	-	-	-	-	-	-	KCK-30N	KCK-50N
With BKN-09+A-5553	-	-	-	-	-	-	KCK-30NF	KCK-50NF



Manual screw extension for quick approach and fine adjustment.



BKD-09: Two piston pump for KCK-30AL and KCK-50 models.



BK-05: One piston pump.

We manufacture two models: The KMG / KSG Monoblock version and the KCK and KSC presses with cylinder and independent pump. Compact and functional design that integrates all the hydraulic elements within the chassis, provides a saving in the workshop space and ensures protection in transport.

Supplied fully assembled and ready for work.
Workbench adjustable for height.
Automatic spring return piston.

Different pump options: single or two speed manual, manual-pneumatic and electric pumps, depending on the working speed required (on KCK and KSC models).

Winch to assist easy and rapid handling of the workbench for model KCK-50A.
Set of two V blocks included and legs with boltholes for fixing to the floor.

Pressure gauge with damper to extend its working life.
It is positioned at eye-level to make for easy reading.

Safety overload valve.
Hydraulic stroke limitation.

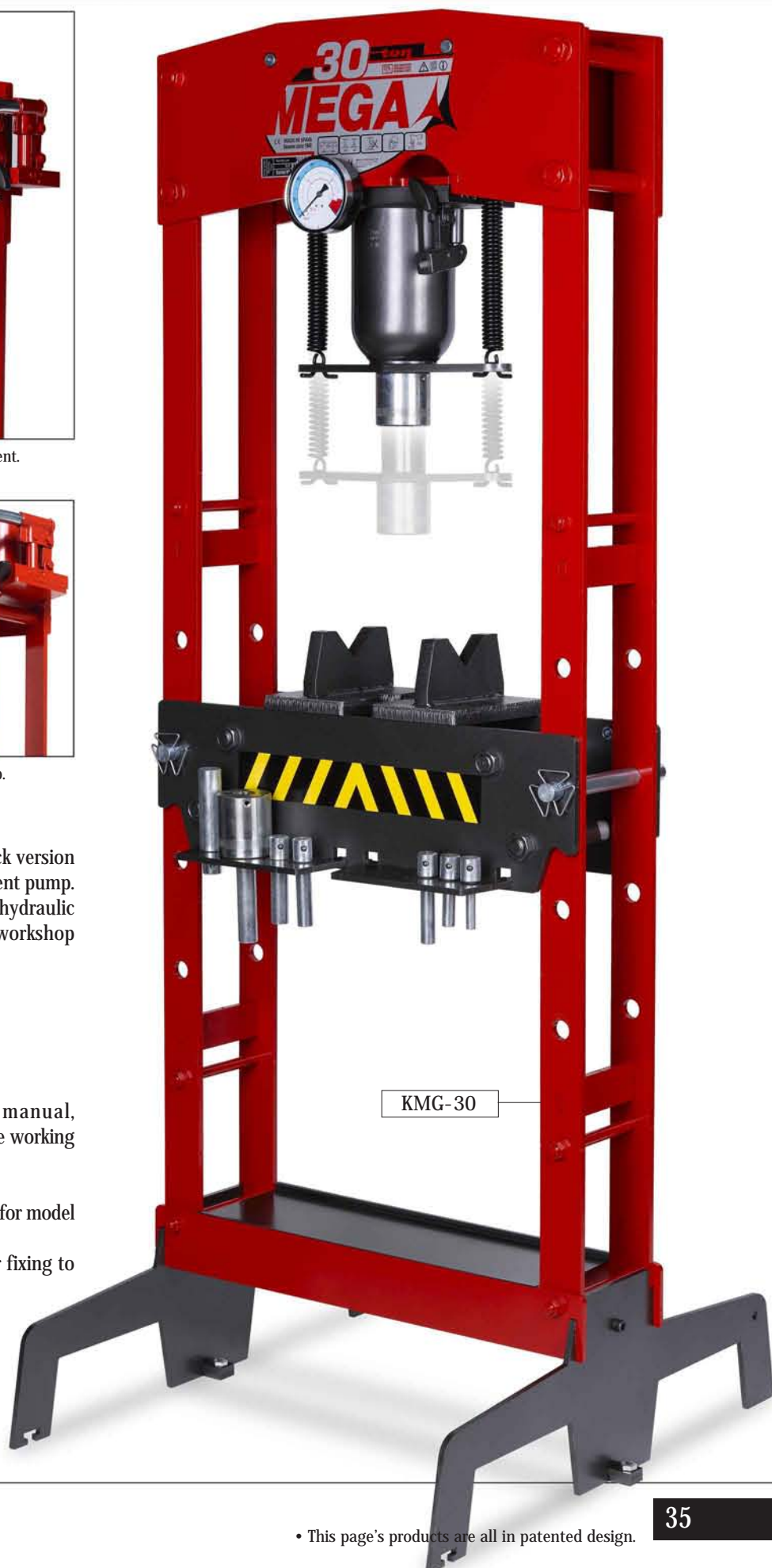

KMG-30